

PART NO.	DIAL FACE COLORS
102-105-1X-X	BLACK BACKGROUND, WHITE CHARACTERS, WHITE ILLUMINATION
102-105-2X-X	WHITE BACKGROUND, BLACK CHARACTERS, GREEN ILLUMINATION
102-105-3X-X	BLACK BACKGROUND, WHITE CHARACTERS, RED ILLUMINATION
102-105-4X-X	BLACK BACKGROUND, WHITE CHARACTERS, GREEN ILLUMINATION

PART NO.	POINTER COLOR
102-105-XB-X	BLACK
102-105-XR-X	RED
102-105-XW-X	WHITE

PART NO.	BEZEL STYLE
102-105-XX-1	BLACK
102-105-XX-2	POLISHED
102-105-XX-3	WHITE
102-105-XX-4	BLACK, AIRCRAFT

102-105-XX-X

DIAL FACE COLORS
POINTER COLOR
BEZEL COLOR & STYLE



P/N 102-105-2R-1
SCALE: 3/4



P/N 102-105-1R-1



P/N 102-105-3W-1
SCALE: 3/4



P/N 102-105-4R-2
SCALE: 3/4

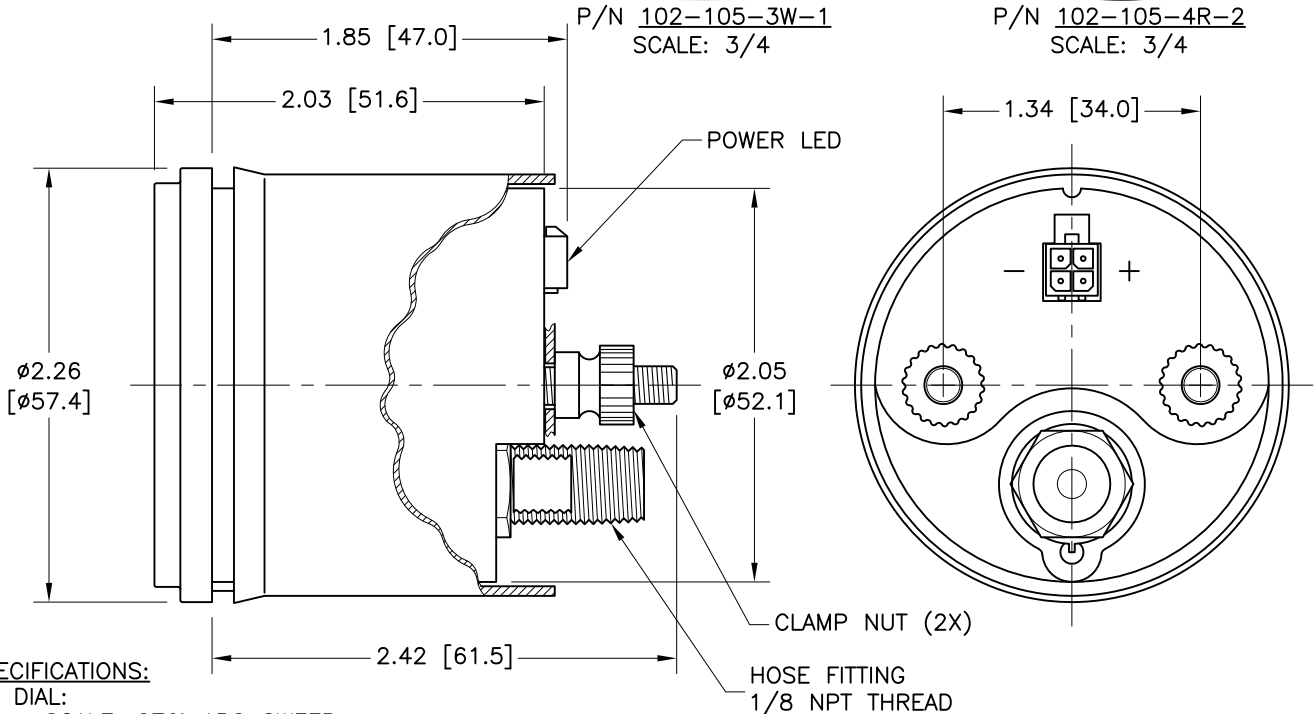

SPECIFICATIONS:

- **DIAL:**
SCALE: 270° ARC SWEEP.
RANGE: 0 - 150 PSI.
- **ILLUMINATION:**
INTERNAL 12 VDC (24 VDC ALSO AVAILABLE).
ILLUMINATED POINTER AND L.E.D. BACKLIT DIAL.
- **POINTER COLOR:**
STANDARD: RED FLUORESCENT (SEE TABLE).

This document involves CONFIDENTIAL proprietary design rights of HEWITT IND. and all designs, manufacturing, reproduction, use and sale rights regarding same are expressly reserved. It is submitted under a confidential relationship and the recipient agrees to assume custody and control thereof and that proprietary information contained herein shall not be reproduced or transferred to other documents or disclosed to others or used for manufacturing or any other purpose without prior written permission of HEWITT IND.

REVISIONS					TOLERANCES	
REV.	DESCRIPTION	EO#	DATE	BY	UNLESS OTHERWISE SPECIFIED:	
					DIMENSIONS ARE IN INCHES, METRIC TOLERANCES ARE IN [BRACKETS]:	
					.X = .050 [1.27]	
					.XX = .030 [0.76]	
					.XXX = .010 [0.25]	
					FRACTIONS = 1/32	
					ANGLES = ±1°	
					SCALE: 1/1	



TITLE: 2" TURBO BOOST PRESSURE GAUGE	
DRAWN BY: JAG	PART NO. 102-105-XX-X
APPR. BY:	SHEET 1 OF 1
DATE: 02/27/12	

A