

FOR CUSTOMER DRAWING  
PART NO. 010-427-1X-X C

| PART NUMBER  | DIAL COLOR                         |
|--------------|------------------------------------|
| 010-427-1X-X | BLACK BACKGROUND, WHITE CHARACTERS |

This document involves CONFIDENTIAL proprietary design rights of HEWITT IND. and all designs, manufacturing, reproduction, use and sale rights regarding same are expressly reserved. It is submitted under a confidential relationship and the recipient agrees to assume custody and control thereof and that proprietary information contained herein shall not be reproduced or transferred to others or used for manufacturing or any other purpose without prior written permission of HEWITT IND.

| PART NUMBER  | POINTER COLOR | PART NUMBER  | BEZEL STYLE   |
|--------------|---------------|--------------|---------------|
| 010-427-1B-X | BLACK         | 010-427-1X-1 | FLAT BLACK    |
| 010-427-1R-X | RED           | 010-427-1X-2 | FLAT POLISHED |
| 010-427-1W-X | WHITE         | 010-427-1X-3 | FLAT WHITE    |
|              |               | 010-427-1X-6 | PLATINUM      |

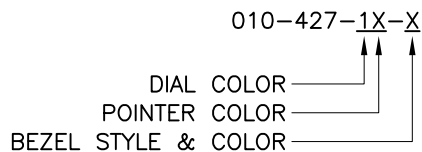

P/N 010-427-1R-1  
SCALE: 1/1

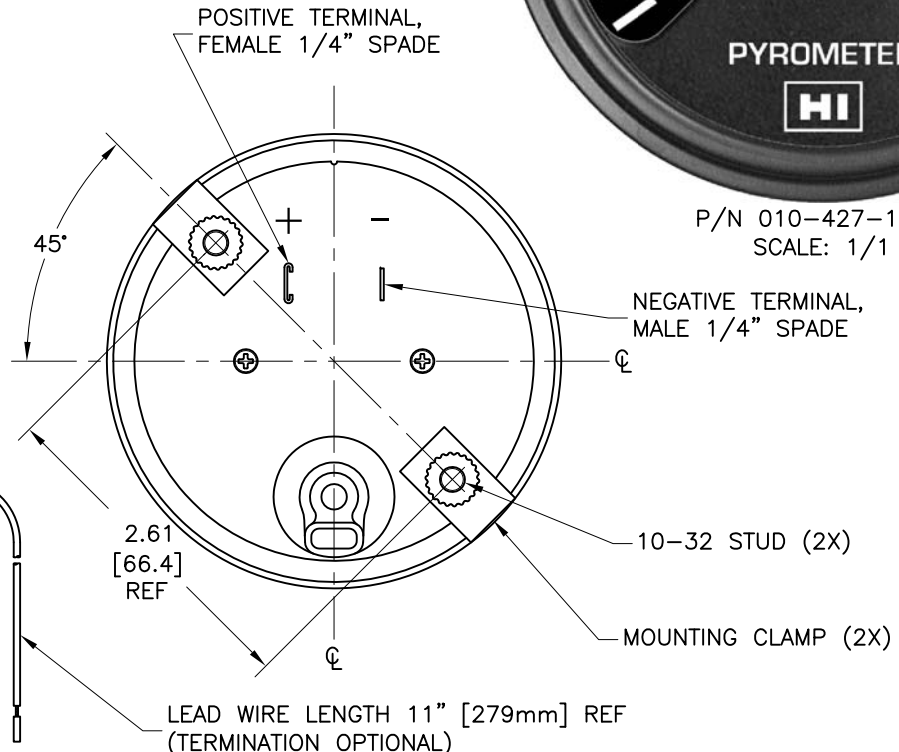
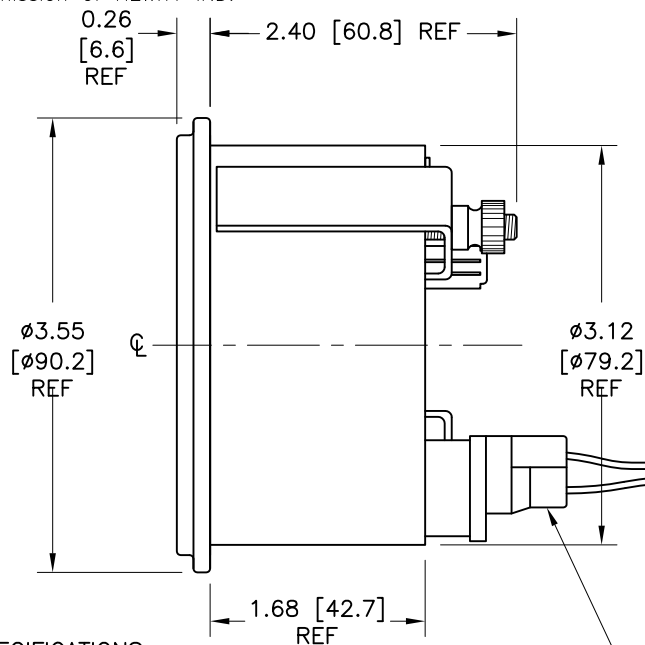

**SPECIFICATIONS:**

- DIAL: 3"  
SCALE ARC: 250° SWEEP.  
RANGE: 0°F - 1500°F.
- ILLUMINATION:  
INTERNAL 12 VDC OR 24 VDC.
- POINTER COLOR: SEE TABLE.
- ACCURACY:  
FULL SCALE: 2%, 2/3 SCALE: 1%.
- CALIBRATION:  
TYPE "K", FOUR OHMS EXTERNAL RESISTANCE.

| REVISIONS |             |     |      |    |
|-----------|-------------|-----|------|----|
| REV.      | DESCRIPTION | EO# | DATE | BY |
|           |             |     |      |    |
|           |             |     |      |    |
|           |             |     |      |    |
|           |             |     |      |    |
|           |             |     |      |    |
|           |             |     |      |    |
|           |             |     |      |    |
|           |             |     |      |    |
|           |             |     |      |    |

| TOLERANCES  |
|---|
| UNLESS OTHERWISE SPECIFIED:   |
| DIMENSIONS ARE IN INCHES,<br>METRIC EQUIVALENTS ARE IN<br>[BRACKETS]: |
| .X = .050 [1.27]  |
| .XX = .030 [0.76]   |
| .XXX = .010 [0.25]  |
| FRACTIONS = 1/32  |
| ANGLES = ±1'  |
| SCALE: 2/3  |

**HI HEWITT INDUSTRIES OF LOS ANGELES**

TITLE: 3" PYROMETER GAUGE

DRAWN BY: JAG PART NO. 010-427-1X-X

APPR. BY: LM

DATE: 05/07/14 SHEET 1 OF 1

A